



- Select a blank which is 229mm (9") diameter and 38mm (1 ½") - 51mm (2") thick. Drill holes at least 38mm deep for mounting the faceplate. True up the edge of the blank and turn the face until the drill holes appear. Sand and finish the face of the blank before removing from the faceplate.
- Remount the blank onto the other face using the same drill holes. Turn the blank to its final thickness of 35mm. Turn the diameter of the blank to 216mm (8 ½"). Round over the edges so the diameter of the face is 203mm (8"). Sand and finish the edge and face of the blank.
- Mark a vertical line in the centre of the blank using a centre finder – make sure the grain of the timber runs horizontally. Using a pair of compasses mark a 145mm diameter circle 21mm from the top of the face using the vertical line as the centre. Mark a horizontal line at the base of the clock (55mm long) using the vertical line to centre it. Centre the faceplate inside the 145mm circle and drill holes all the way through the blank.
- Mount the blank onto the faceplate – it will now be eccentric (off-centre) so care should be taken when turning. Mark a 140mm circle onto the face. Using a parting tool cut approx. half way through the blank.
- Remount the blank onto the other face using the same drill holes for the faceplate. Secure the back of the blank with masking tape. Mark a 145mm circle and a 140mm circle onto the face. Use a parting tool to cut the 145mm circle 10mm deep to accept the rim of the clock. Slow the lathe down and cut the 140mm circle all the way through. Remove the blank from the lathe and if necessary sand the inside.
- Cut or sand the base flat along the 55mm long line. Unscrew the face of the skeleton clock mechanism and fit into the timber recess. Ensure that the face of the clock is vertically aligned. Then mark and drill holes for the four retaining clips. Remove the protective cover from the back of the clock and screw into place.

Hints & Tips

To accurately locate a faceplate draw a small circle slightly larger than the faceplate to align to.

For a long lasting high gloss finish apply pure carnauba wax using a buffing wheel.

Use a set square to help vertically align the clock face.

For more project instructions visit:

www.ockenden-timber.co.uk



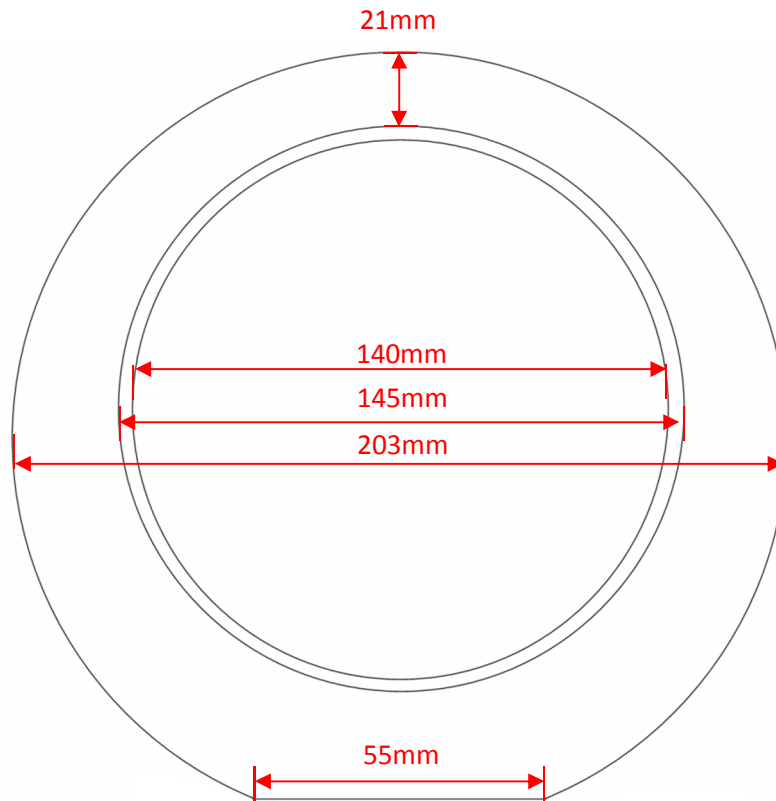

Disclaimer: All information, sizes and diagrams are for use as a guide only.
Ensure that you follow all current health & safety legislation.

For more project instructions visit:

www.ockenden-timber.co.uk

